

Code: 23ES1401

**II B.Tech - II Semester – Regular / Supplementary Examinations
APRIL 2026**

**ANALOG CIRCUITS
(ELECTRICAL & ELECTRONICS ENGINEERING)**

Duration: 3 hours

Max. Marks: 70

- Note: 1. This question paper contains two Parts A and B.
 2. Part-A contains 10 short answer questions. Each Question carries 2 Marks.
 3. Part-B contains 5 essay questions with an internal choice from each unit. Each Question carries 10 marks.
 4. All parts of Question paper must be answered in one place.

BL – Blooms Level

CO – Course Outcome

PART – A

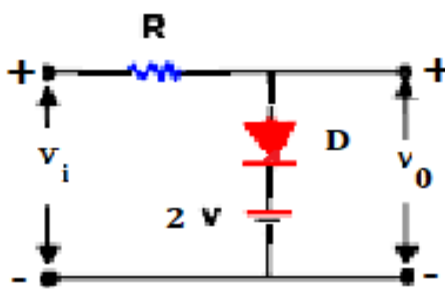
		BL	CO1
1.a)	Draw the two circuits of clamping.	L1	CO1
1.b)	Draw the output waveform of the given clipper circuit with a sinusoidal input signal of 10Vp-p. Assume diode is ideal. $V=2V$, $R=1k\Omega$	L2	CO1
			
1.c)	Draw the exact h-parameter model of BJT in CE configuration.	L1	CO1
1.d)	Explain the effect of emitter bypass capacitor on frequency response of a CE amplifier.	L2	CO2
1.e)	Sketch the equivalent circuit of a Crystal.	L2	CO1
1.f)	Draw the circuit diagram of Op-amp inverting adder and write the expression for its output voltage.	L3	CO1

1.g)	For the given uA741 OP-AMP, operating in voltage Follower configuration, having $2V_{P-P}$ sinusoidal input, find the maximum frequency up to which it produces undistorted output.	L3	CO3
1.h)	Why level translator circuit is required in OP-AMP block diagram. Explain.	L2	CO2
1.i)	List the applications of 555 timer.	L1	CO5
1.j)	An 7 bit D/A converter has a resolution of 20mv. Find the full scale voltage and output voltage when the input is 1101110.	L2	CO4

PART – B

			BL	CO	Max. Marks
UNIT-I					
2	a)	With the help of a neat circuit diagram, explain the working of a two level diode clipper and draw the output waveform.	L3	CO3	5 M
	b)	Derive the expression for Stability factor of Self bias circuit.	L3	CO4	5 M
OR					
3	a)	In a CE germanium transistor amplifier circuit, the bias is provided by self-bias. The various parameters are $V_{cc}=16v$, $R_c=3k\Omega$, $R_1=10k\Omega$, $R_2=90k\Omega$, $R_E=2k\Omega$, $\alpha=0.975$. Determine i) coordinates of Q-point ii) stability factor.	L4	CO4	5 M
	b)	What is negative clamping and explain its working principle with input and output waveforms.	L3	CO3	5 M

UNIT-II

4	a)	Derive the simplified CE h-parameter model from its exact h-parameter model.	L4	CO4	5 M
	b)	A CE amplifier has h-parameters given by $h_{ie}=2000\Omega$, $h_{re}=2 \times 10^{-4}$, $h_{fe}=80$, $h_{oe}=25 \times 10^{-6}$ mho. If both load and source resistances are $1k\Omega$. Determine i) Current gain A_I ii) Voltage gain A_v	L4	CO4	5 M

OR

5	a)	Analyze BJT CE amplifier using exact h-parameter model to derive its voltage gain, current gain and input impedance.	L4	CO4	6 M
	b)	Explain the low frequency response of a CE amplifier describing the effect of bypass capacitor, coupling capacitor and internal capacitors.	L3	CO3	4 M

UNIT-III

6	a)	Derive the expression for frequency of oscillation of RC-phase shift oscillator.	L4	CO4	6 M
	b)	Explain the Ideal characteristics of an Op-Amp in detail.	L2	CO2	4 M

OR

7	a)	Define and discuss about the AC characteristics of Op-Amp.	L4	CO4	3 M
	b)	What is a Crystal Oscillator? Explain its operation and advantages.	L3	CO3	7 M

UNIT-IV					
8	a)	Draw the Op-Amp Subtractor circuit and derive the expression for its output voltage.	L4	CO4	4 M
	b)	Discuss the operation of basic integrator using Op-Amp with neat sketches.	L3	CO3	6 M
OR					
9	a)	Describe the working of an Op-Amp square wave generator with the help of neat circuit diagram and waveforms.	L3	CO3	5 M
	b)	Explain the working of an Instrumentation Amplifier using three Op-Amps with a neat circuit diagram.	L3	CO3	5 M
UNIT-V					
10	a)	Explain the following specifications of Data converters: Resolution, Monotonicity, Settling time and Conversion time.	L2	CO2	4 M
	b)	Describe the operation of 555 timer with the help of its functional block diagram.	L3	CO5	6 M
OR					
11	a)	Discuss the function of a Voltage Controlled Oscillator and explain its applications.	L3	CO4	4 M
	b)	Explain the operation of Successive approximation type A/D converter with neat block diagram.	L3	CO5	6 M